

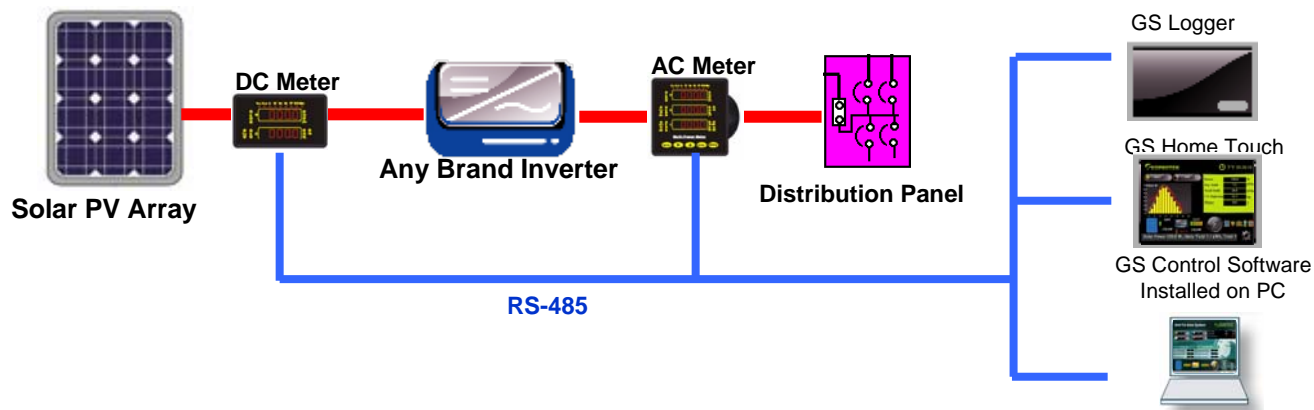

Digital Power Meter

In some case, user need to monitor the solar system that is not used GS Inverter or other support inverter devices. GS Logger, GS Home Touch and GS Control Software supports the digital power meters in DC side and AC side to monitor the Vdc, Idc, Pdc, E-Total-dc(kWh), Vac, Iac, Pac, E-Total-ac(kWh). The disadvantage is that you can't monitor the inverter alarm status or other parameters ex: Fac, Zac, efficiency,...etc. The advantage is that you can use in more situation that the solar system is not using GS Inverters.





DC Power Meter (MP-84DH)

- Max. display 8 digits (KWH)
- Max. Display 4 digits can change V,A,KW
- PTxCT rate free setting
- RS-485 interface
- Din case 96x48mm

Order Code _____ **MP84DH-**
Input DCV _____
 1: 0~10V, 2: 0~100V, 3: 0~300V, 4: 0~500V
Input DCA _____
 1: 0~5A, 2: 0~15A, 3:0~20A, 4: 0~50A, 5: 0~75A, 6: 0~100A
Power Supply. _____
 1: AC 115/230V±10%, 50/60Hz



AC Power Meter (MP-12THR, MP-13THR, MP-33THR, MP-34THR)

- Max. display 8 digits (KWH)
- Max. Display 4 digits can change V,A,KW
- PTxCT rate free setting
- RS-485 interface
- Din case 96x48mm

Order Code _____ **Model-**
Model Name _____
 MP12THR: 1 Φ2W
 MP13THR: 1 Φ2W
 MP33THR: 3 Φ3W
 MP34THR: 3 Φ4W
Input ACV _____
 1: 120V, 2: 240V, 3: $\sqrt{3}$ ·120V/120V, 4: $\sqrt{3}$ ·240V/240V
Input ACA _____
 1: 0~5A, 2: 0~25A, 3:0~50A, 4: 0~100A, 5: 0~200A, 6: 0~400A
Power Supply. _____
 1: AC 115/230V±10%, 50/60Hz



Multi Power Meter (CP500)

- Display of all the electric parameters V, A, W, Var, VA, PF, Hz, WH, VarH ect.
- True RMS conversion.
- Maximum function.
- Field programmable PT and CT ratio.
- Memory for all setup and energy data.

Order Code _____ **CP500-**
Input ACV _____
 1:600VL-L / 347VL-N
Input ACA _____
 1: 0~5A, 2: 0~25A, 3:0~50A, 4: 0~100A, 5: 0~200A, 6: 0~400A
Power Supply. _____
 1: AC 90~260V, 50/60Hz, 2:DC 24V, 3:DC 120V

